

Celebrating 50 Years
of Engineering Excellence

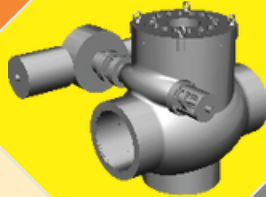

50 Years
1964-2014



VALVES PRODUCT RANGE

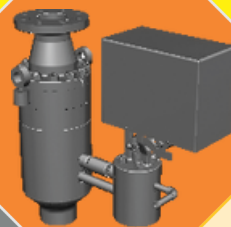
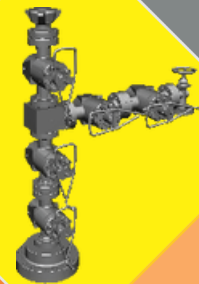
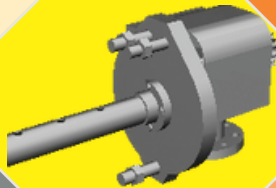
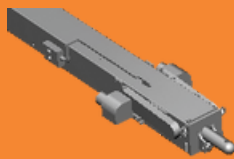

VALVES PRODUCT RANGE

Corporate Profile

Bharat Heavy Electricals Limited (BHEL) is India's largest engineering and manufacturing company of its kind engaged in the design, engineering, manufacture, construction, testing, commissioning and servicing of a wide range of products, systems and services for the core sectors of the economy. BHEL manufactures over 180 products under 30 major product groups that cater to the needs of the power, transmission, industry, transportation, renewable energy, oil and gas, telecommunications, non-conventional energy sectors and defence. BHEL has 17 manufacturing units, 2 repair units, 4 regional offices, 8 service centres, 8 overseas offices, 15 regional centres, 7 joint ventures, and infrastructure to execute more than 150 project sites across India and abroad. BHEL's products, services and projects have been exported to over 76 countries worldwide in all six inhabited continents of the world.

BHEL has turnkey 'concept-to-commissioning' capability for executing power projects, with proven, operational project installations of over 1,24,000 MW for utility, captive power and industrial applications.

BHEL Tiruchirappalli

BHEL Tiruchirappalli Complex comprises the High Pressure Boiler Plant, the Seamless Steel Plant, the Welding Research Institute located at Tiruchirappalli, the Power Plant Piping Unit at Thirumayam, the Piping Centre at Chennai, and the Industrial Valves Plant at Goindwal (Punjab).

Valves

BHEL Tiruchirappalli manufactures valves to the highest international standards for a wide range of critical applications in the power, industry and oil & gas sectors.

BHEL's Industrial Valves Plant (IVP) at Goindwal manufactures Gate Valves, Globe Valves, Swing-check Valves of various materials from carbon steel to stainless steel with special features like motorized or geared operation, limit switch and indicator arrangement, lock or chain-wheel, etc.

Widest range of valves

BHEL's product range includes Gate, Globe and Non-return Valves, Angle drain & Blow down Valves, Safety Valves and Safety Relief Valves, Electrical Relief Valves, Quick Closing Non-return Valves, Cold Re-heat Line Non-return Valves, Forged Steel Valves, HP-LP Bypass Systems, Soot Blowers, Wall De-slaggers, Water Level Gauges and Oil-field Equipment such as Well-heads, X-mas Trees, Block Valves, Mud-line Suspension Systems and Choking Manifold.

Meeting world standards

BHEL valves conform to international codes such as ASME, API, ANSI, DIN and IBR. BHEL High Pressure Cast Steel Valves and Quick Closing Non-return Valves are manufactured with technology from TOA Valve Company (Japan), Forged Steel Valves, Safety Valves, Safety Relief Valves, Electrical Relief Valves and Y-type Valves with technology from Dresser Industries Inc., (USA), Oil-field equipment with technology from Kvaerner National (USA), HP-LP Bypass Systems with technology from Sulzer Thermtec (Switzerland) and Soot Blowers with technology from Copes-Vulcan (USA).

Sophisticated manufacturing and testing facilities

BHEL's valves production shops are equipped with state-of-the art CNC machines capable of performing intricate operations. Testing facilities include radiographic testing for castings and forgings, a full-fledged steam testing station for Safety Valves and Safety Relief valves, hydraulic test benches and an air-test station for conventional valves, besides hydraulic testing facilities for High Pressure Valves and testing facilities for Oil-field Equipment up to 22,500 psi.

Focus on quality

BHEL is known for its international Quality standards, has certified Quality Management Systems (ISO 9001:2008 CE), Environmental Management Systems (ISO 14001:2004), Occupational Health & Safety Management Systems (OHSAS 18001:2007), Information Security Management Systems (ISO 27001) and is well on its way towards Total Quality Management.

Continuous design improvements through in-house research & development (R & D), quality management systems and state-of-the-art precision manufacturing technology ensure that BHEL valves set the standards for quality and reliability.

Quality Assurance services are provided by a team of qualified scientists equipped with advanced diagnostic and measuring equipment including spectrometers, high magnification microscopes, x-ray diffraction strain gauges besides fatigue and creep testing machines. Non-destructive testing facilities use X-rays up to 400 KV and isotopes up to 800 Curies. Precision gauges, tools and instruments are calibrated at BHEL's in-house nationally accredited Calibration Centre.



High Pressure Gate Valve

- Pressure Class: 1500 to 3500
- Material: WCC, WC9 & C12A
- Size: 2½" to 24"

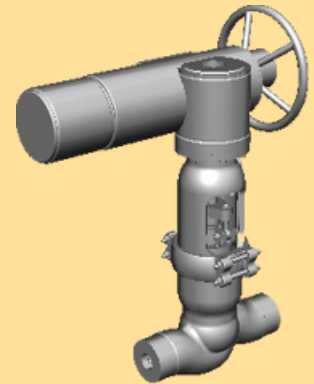

High Pressure Globe Valve

- Pressure Class: 1500 to 3500
- Material: WCC, WC9 & C12A
- Size: 2½" to 10"

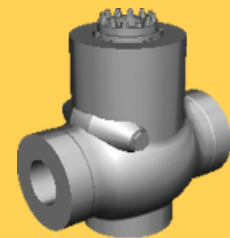

High Pressure Check Valve

- Pressure Class: 1500 to 3500
- Material: WCC, WC9 & C12A
- Size: 2½" to 24"



Re-heater Isolating Device

- Pressure Class: 500, 900, 1500
- Material: WCB, WCC, WC9, C12A
- Size: 18", 20", 22", 28", 30", 32"

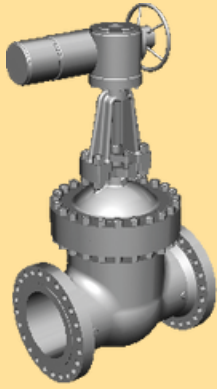

Cast Steel Gate Valve

- Pressure Class: 150, 300, 600
- Material: WCB, WC9, WCC, C12A & CF8M
- Size: 2" to 38"



Cast Steel Globe/Regulating Valve

- Pressure Class: 300, 600
- Material: WCB, WCC, WC9, C12A & CF8M
- Size: 2" to 16"

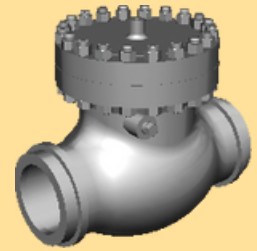

Cast Steel Non-return Valve

- Pressure Class: 150, 300, 600
- Material: WCB, CF8M, WC9, WCC
- Size: 2" to 38"



Forged Steel Medium Pressure Gate Valve

- Pressure Class: 800
- Material: A105, F316
- Size: ¼" to 2"

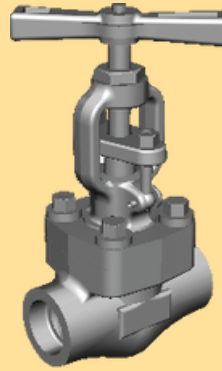

Forged Steel Medium Pressure Globe Valve

- Pressure Class: 800
- Material: A105, F316
- Size: ¼" to 2"

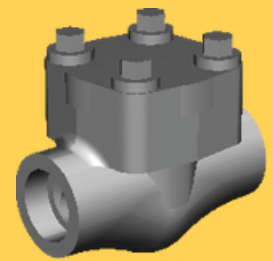

Forged Steel Medium Pressure Check Valve

- Pressure Class: 800
- Material: A105, F316
- Size: ¼" to 2"

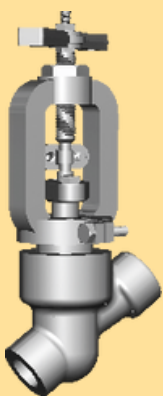

Y-type Globe Valve

- Pressure Class: 2500
- Material: A105
- Size: 2½"



Forged Steel Blow Down Valve

- Pressure Class: 800, 1500, 2000, 2750
- Material: A105; Size: 1", 1½"
- Orifice: ¾" to 1"

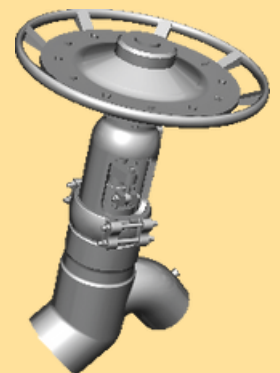

Elbow Down Valve

- Pressure Class: 2000
- Material: WCC
- Size : 12"

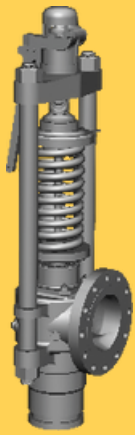

Safety Valve

7000 Series

- Pressure: 600 to 5300
- Material: WCB, WC6, WC9 & C12A
- Size: 1½" to 6"

7800 Series

- Pressure Class: 300 to 900
- Material: WCB, WC6, WC9
- Size: 1¼" to 6"



Safety Relief Valve

9000 Series

- Pressure Class: 150 to 2500 psi
- Material: WCB, WC6, CF8M
- Size: 1" to 8"



Portable Relief Valve

- Pressure: 150 to 8000 psi
- Material: WCB, CF8M
- Size: ½" to 2"

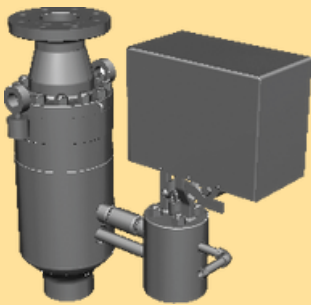

Electrical Relief Valve

- Pressure Class: 1500, 2500, 3000 psi
- Material: WC9, C12A
- Size: 2½", 6"



Silencer

- Absorptive & Reactive type
- Insertion loss: 25 to 40 dbA
- Size: 500 to 2700 mm OD



Angle Drain Valve

- Size: 25/40, 25/65, 40/50, 40/65, 50/65 & 65/100
- Ratings: C1500 to C3000 Spl
- Material: SA 105, F22 & F91

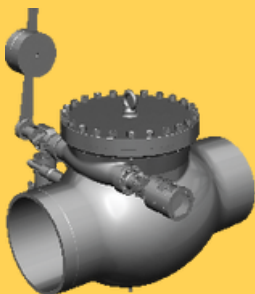

Quick Closing Non-return Valve

- Pressure Class: 150 to 900
- Material: WCB, WC6, WC9
- Size: 3" to 32"

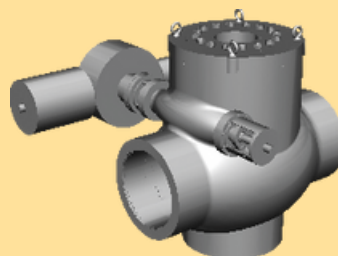

Cold Reheat Line Non-return Valve

- Pressure Class: 600, 900
- Material: WC6, WC9
- Size: 18", 24", 32"



Pressure Gauge Valve

- Pressure Class: 1500 to 4000
- Material: SS 316
- Size: 3mm
- End conn. M20/G0.5/R0.5/0.5NPT



Well Head

- Pressure Rating: 2000, 3000, 5000, 10000, 15000 psi
- Two, Three & Four casing
- Single and Multiple string
- PSL: 1 to 4
- Material Class: AA through HH

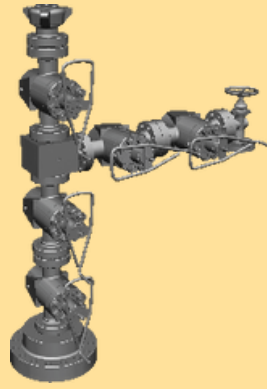

X-mas Tree

- Pressure Rating: 3000, 5000, 10000 psi
- Size: 2 1/6", 3 3/8", 4 1/16", 5/8"
- Single Arm, Double Arm
- PSL: 1 to 4
- Material Class: AA through HH

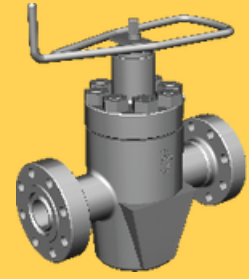

Full Bore Gate Valve

- Pressure Rating: 2000, 3000, 5000, 10000, 15000 psi
- Material: Alloy Steel
- Size: 1 3/16", 1/2", 2 1/16", 3/8", 4 1/16", 5/8"



Adjustable Choke

- Pressure Rating: 5000, 10000 psi
- Size: 2 1/6", 3/8", 4 1/16", 5/8" as per customer's requirement

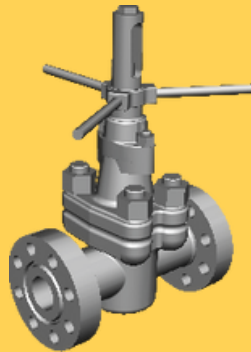

Mudline Suspension

- Pressure: 5000 psi
- Size: 2 1/16" & 4 1/16"



Low Pressure Turbine Bypass Valve

- Available for 110, 210 MW
- Turbine sets for 30% flow
- Hydraulic actuator operated with automatic controls

High Pressure Turbine Bypass System



Angle-type HP Bypass Valve

- High Pressure turbine bypass valves
- Spray water valves
- Electro-hydraulic actuators
- Position feedback transmitters
- Proportional valves/Servo valves
- Hydraulic power packs



Z-type HP Bypass Valve

- Maximum Design Pressure: 280 kg/cm²
- Maximum Design Temperature: 573OC
- Standard Flow capacities: 30%, 60%, 65% and 100% of TMCR
- Designs for higher parameters/ Intermediate flow capacities available on request

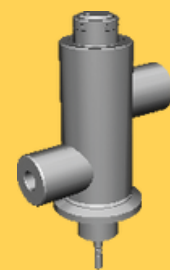

Spray Valves

- Maximum Design Pressure: 350 kg/cm²
- Maximum Design Temperature: 300OC
- Design for higher parameters available on request

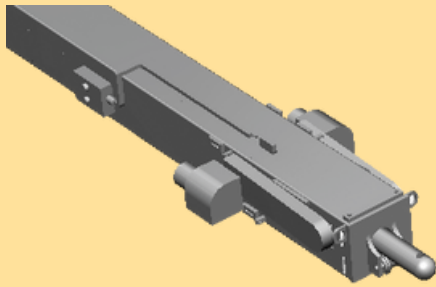

Long Retractable Soot Blower

- Travel up to 12.2 metres
- Blowing medium Steam/ Compressed Air
- Drive Electric motor/Air motor
- Non-Flame Proof & Flame Proof
- Models: LRS IE, LRD IE, LRD IIE, HRS IE, HRD IE, LRD IER, LRNR

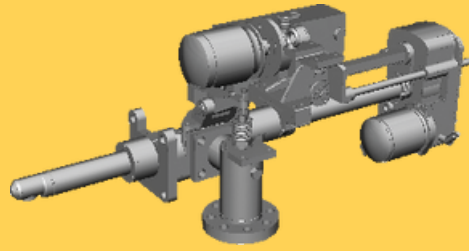

Wall Deslagger

- Travel 305 mm
- Blowing medium Steam/ Compressed Air/Water
- Drive Electric motor

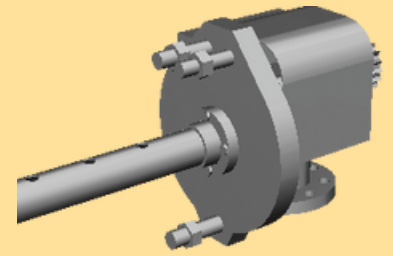

Rotary Soot Blower

- Blowing medium Steam/ Compressed air
- Drive Electric motor/ Air motor/Manual
- Non-Flame Proof & Flame Proof
- Blowing elements CS/SS

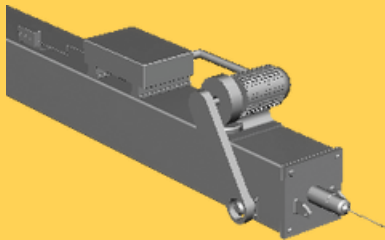

Temperature Probe

- Travel upto 7.2 metres
- Models Air cooled/Non-cooled
- Max. temp. measurement: 815OC with air cooling
- Drive Electric Motor

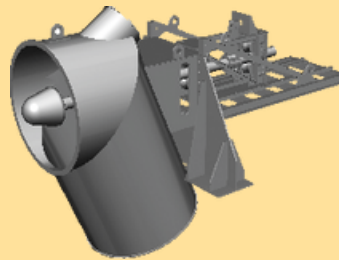

Ash Discharge Valve Seal-pot

- Located at Seal pot in CFBC boiler
- Lance Size: 135 mm
- Stroke: 300 mm

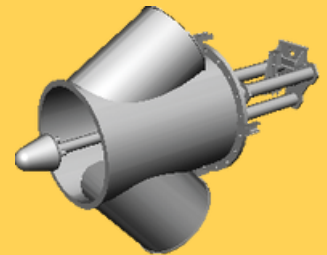

Ash Discharge Valve Combustor Chamber

- Used in Combustor chamber of CFBC boiler
- Lance Size: 75 mm
- Stroke: 300 mm

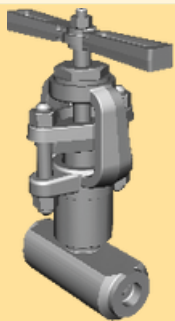

Forged Steel High Pressure Globe/Regulating Valve

- Pressure Class: 1500, 2500, 3000 SPL, 3000 LTD & 4500
- Material: A105, F22, F91, F316
- Size: ¼" to 2"



Forged Steel High Pressure Check Valve

- Pressure Class: 1500, 2500, 3000 SPL, 3000 LTD
- Material: A105, F22, F91, F316
- Size: ¼" to 2"



Floating and Trunnion type Ball Valves

- Rating: C300
- Seat: Metal Seated
- Size: 2" - 8"

Celebrating 50 Years of Engineering Excellence



5Years

